



echeuch
CAMCORP SCHUST

REVERSE AIR DUST COLLECTORS

INNOVATIVE AIR POLLUTION CONTROL SYSTEMS FOR
INDUSTRIAL ENVIRONMENTS

The HVP and SWF Series Reverse Air Dust Collectors are the best solution for industries with high air volumes and significant dust loads, such as processing and manufacturing. Camcorp is the industry leader in standard sizes and customizable configurations to address virtually all dust collection challenges, with capacities exceeding 250,000 CFM.

SOLUTIONS FOR EVERY STAGE OF YOUR SYSTEMS PERFORMANCE

WE SERVE A SEVERAL INDUSTRIES

- Agriculture
- Foundry
- Recycling
- Brewing
- Grain
- Rock Products
- Cement
- Iron and Metals
- Seed and Feed
- Chemical
- Milling and Baking
- Woodworking
- Coal
- Mining and Minerals
- Ethanol
- Paper
- Feed
- Pet Food
- Fly Ash
- Food Processing

STANDARD FEATURES

- All-welded housing to reduce set-up time and minimize installation costs.
- Heavy-duty carbon steel construction rated at +/- 20" W.C.
- Exterior and clean air plenum interiors are primed and finished with white acrylic polyurethane.
- A walk-in clean air plenum with hinged access door provides convenient access to filter bags and internal cleaning system components.
- Tool-free bag and cage installation and removal are quick and easy.
- Standard round clean-air exhaust outlet (square or rectangular optional), each sized as required.
- A selection of inlet designs is available. (High entry inlets with formed staggered channel baffles are illustrated.)
- Conical hopper with 60-degree side slope, access port, and flanged discharge
- Depending on size and clearance requirements, structural supports are welded to the all-welded housing to reduce set-up time and minimize installation costs.

COMMON ACCESSORIES & OPTIONS

- Stainless steel construction
- Flanged or sectionalized fabrication
- Tangential, involute, or custom inlets
- Wide selection of bag filter medias
- Pleated filter elements
- Sprinkler kits
- Hopper access doors
- Explosion venting
- 70° side slope hopper
- Platforms and ladders
- Live-bottom anti-bridging augers
- Rotary valves
- Slide gates and drum cover kits
- Dust bins
- Fans, dampers, and silencers
- Photohelic or Magnehelic gauges
- Motor starters and electrical control panels
- NEMA 7/9 explosion proof electrical
- High-temperature designs
- High pressure/vacuum rating



SWF REVERSE AIR DUST COLLECTOR

The SWF Series Reverse-Air Filter is a continuous duty, low pressure, self-cleaning dust collector.

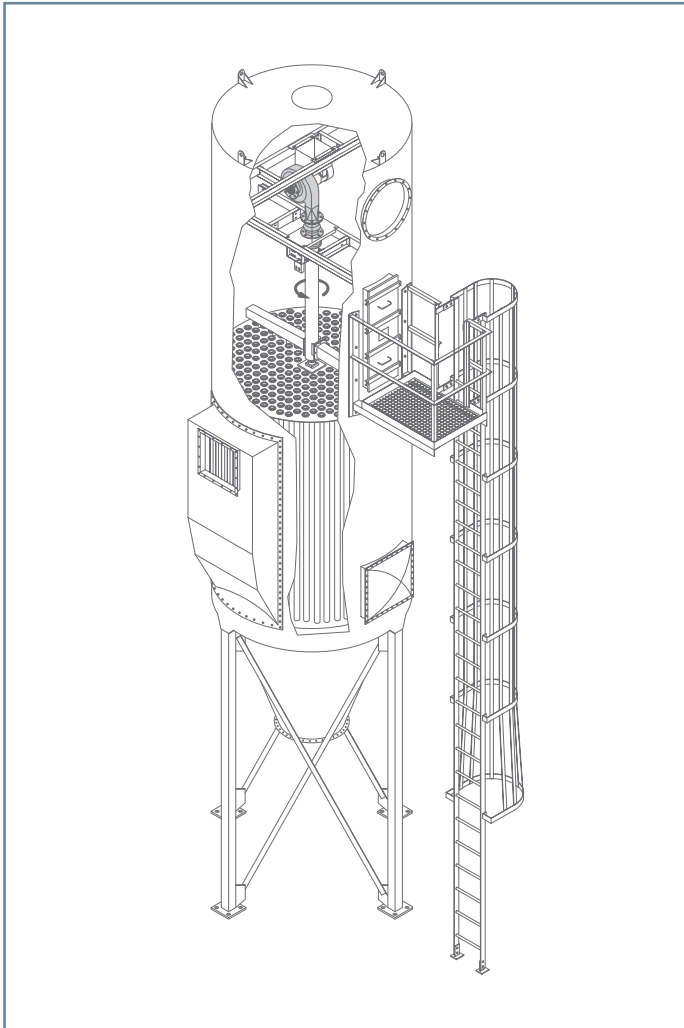

SWF Reverse Air Collectors use low-pressure air, an energy-efficient centrifugal pressure blower fan, and a rotational cleaning air manifold system to clean the reverse air bag filters.

HVP REVERSE AIR DUST COLLECTOR

The HVP Series Reverse-Air Filter is a continuous duty, medium pressure, self-cleaning dust collector.

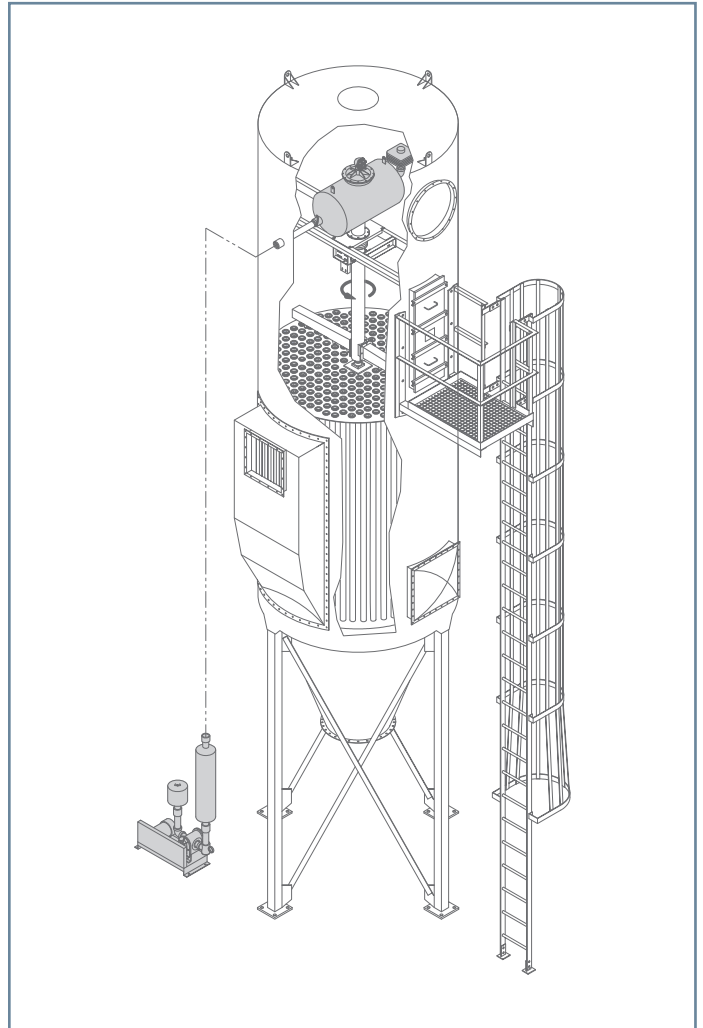

HVP Reverse Air Collectors use an energy-efficient, medium-pressure air (7 ½ PSI), bag filter cleaning system. It has a rotary lobe, a positive displacement blower, an air accumulator tank with a diaphragm valve, a solenoid valve, an adjustable timer, and a rotational cleaning air manifold.



Scheuch North America
15975 College Boulevard
Lenexa, KS 66219
Phone: 913-951-8586
Website: scheuch-usa.com

Schust
4483 County Road 19
Auburn, IN 46706
Phone 260-925-6550
Phone: 800-408-4820
Website: schust.com

Camcorp
15975 College Boulevard
Lenexa, KS 66219
Phone: 913-831-0740
Website: camcorpinc.com